

Since the usage and finishing of the product is not under our control, we accept no liability for the success of the work and can therefore only guarantee the nature of our products as per the accompanying product data sheets and in accordance with our general terms and conditions of sale. The properties listed here represent no guarantee with respect to the eventual use of our products. We reserve the right to make changes due to technical advances. Any other technical information given in the course of a consultation must be confirmed in writing. Colours shown here are restricted by the printing techniques and may differ from those exhibited by the products themselves. We also reserve the right to make alterations to the product technology or design. Only the current version of this data sheet is valid. Such versions are accessible by anyone via the internet. The issue of the latest data sheet invalidates all those that have been published beforehand.

DURASTEP Jumbo

1/2

Anti-slip step nosing for ceramic tiles
Width: 35 mm

DURAL

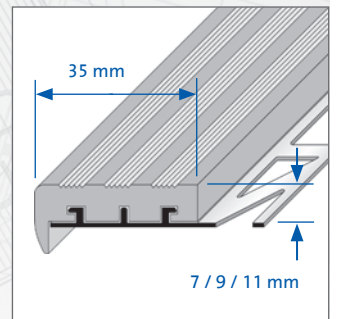
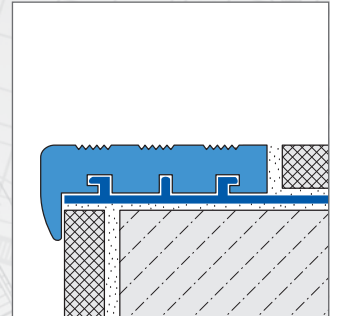

APPLICATION:

DURASTEP Jumbo Profiles by Dural are stair nosings designed for business and public buildings. The application is recommended for where a high level of foot traffic is to be expected. DURASTEP Jumbo Profiles are designed to be - resistant to stresses, anti slip and to be visually appealing. The profiles were designed so that the tread surfaces can be replaced. Thus optimum safety can be provided at all times. The edges of the stairs are also permanently protected by DURASTEP Jumbo. All versions correspond to the maximum safety standards. The stair profiles are also authorised for application in working areas with skid risk, (BIA Test Certificate, anti-skid evaluation group R10). DURASTEP Jumbo Profiles are provided with a 5-year guarantee on the PVC-Top.

MATERIAL:

DURASTEP Jumbo Profiles are available in the following colours: white, beige, black, brown and grey. The profiles consist of an aluminium carrier profile and PVC tread. The invisible base section is made of hard PVC, the slide-blocking surface of soft PVC. Width is of 35 mm.

PROPERTIES:

DURASTEP Jumbo Profiles were especially designed for areas subjected to heavy stress. Because the carrier profile is made of aluminium the following is to be observed: The stair profiles can be used any place where no unusual chemical reaction is to be expected. Careful handling with cement materials is required to avoid corrosion. Aluminium is susceptible to alkaline mediums. The profile must be completely embedded into the contact layer. This avoids the generation of hollow sections where water might accumulate.

DURAL GmbH & Co. KG

Südring 11

D-56412 Ruppach-Goldhausen

Tel. +49 (0) 2602/9261-0

Fax +49 (0) 2602/9261-50

welcome@dural.de

DURASTEP Jumbo

2/2

DURAL

Anti-slip step nosing for ceramic tiles Width: 35 mm

For all products and materials, the following applies: The suitability of the material with regard to the expected mechanical loading and chemical exposure must be investigated carefully in each individual case. The generally recognised rules of good engineering practice must always be observed!

INSTALLATION:

1. Select DURASTEP Jumbo Profile according to the tile thickness.
2. Fix the riser tile to the appropriate height.
3. Apply tile cement in the step edge area using a notched trowel.
4. Press the carrier profile well into the cement bedding and align the front edge flush with the riser.
5. Apply cement to the step tread area ensuring the fixing leg of the profile is solidly embedded.
6. Solidly bed tread tiles and align them flush with the upper profile edge.
7. Leave a joint of 2 mm between the profile and first row of tiles.
8. Fill the space between tiles and profile completely with joint grout.

CARE AND MAINTENANCE:

DURASTEP Jumbo Profiles do not require any special care. Dirt deposits can be removed with the usual commercial cleaning materials. The cleaning materials must not contain hydrochloric acid and hydrofluoric acid and must not be abrasive. If required, it is possible to replace the tread surface.

PRODUCT DATA:

MATERIAL:	Aluminium with PVC insert
INSERT COLOUR:	white / beige / black / brown / grey
LENGTH:	100 / 250 cm
HEIGHT:	7 / 9 / 11 mm
WIDTH:	35 mm

DURAL GmbH & Co. KG
Südring 11
D-56412 Ruppach-Goldhausen
Tel. +49 (0) 2602/9261-0
Fax +49 (0) 2602/9261-50
welcome@dural.de