

Since the usage and finishing of the product is not under our control, we accept no liability for the success of our products as per the accompanying product data sheets and in accordance with our general terms and conditions of sale. The properties listed here represent no guarantee with respect to the eventual use of our products. We reserve the right to make changes due to technical advances. Any other technical information given in the course of a consultation must be confirmed in writing. Colours shown here are restricted by the printing techniques and may differ from those exhibited by the products themselves. We also reserve the right to make alterations to the product technology or design. Only the current version of this data sheet is valid. Such versions are accessible by anyone via the internet. The issue of the latest data sheet invalidates all those that have been published beforehand.

DURATRANS

1/2

Transition profile designed to compensate for differences in height of up to 12.5 mm

DURAL

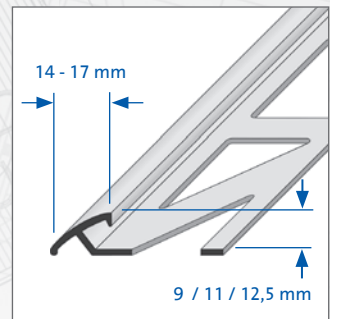
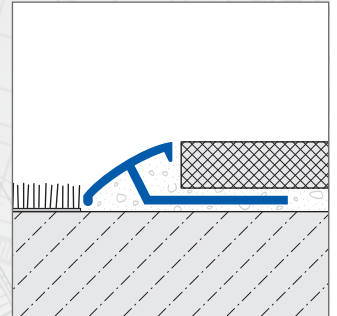

APPLICATION:

DURATRANS transition profiles from Dural are used to compensate for differences in height between two flooring surfaces such as those which might occur between a tiled floor and a carpeted floor, for example. DURATRANS provides a smooth inclined junction between the two, which also protects the edges of the tiles from any damage.

The shape and material have been selected so that these profiles are also able to withstand a great deal of stress. Loads acting at a point are distributed evenly through the floor and the foundations. Thanks to the exceptional stability of the profiles, they are highly suited for use in busy areas such as public buildings or shopping centres. They may also be used in the open air (such as for doorways and garage entrances).

DURATRANS profiles of this design are slightly curved for the benefit of usage in homes etc. This type is available for heights of up to 12.5 mm and is also available as the flexible "Z-Flex variant".

MATERIAL:

DURATRANS profiles provide height compensation for differences of up to 12.5 mm and available in the following finishes: natural aluminium, anodised aluminium silver, natural brass and highly polished brass („Star“ with peel-off strip).

PROPERTIES:

DURATRANS aluminium profiles can be used wherever unusual chemical reactions are not to be expected. To prevent corrosion care must be taken with the application of cement and mortar. Since aluminium is sensitive to alkaline materials, mortar, tile adhesive and grout must be cleaned immediately from all visible surfaces. The profile needs to be thoroughly embedded in the contact layer. This prevents the formation of air pockets where alkaline solutions of water could collect.

DURAL GmbH & Co. KG

Südring 11

D-56412 Ruppach-Goldhausen

Tel. +49 (0) 2602/9261-0

Fax +49 (0) 2602/9261-50

welcome@dural.de

Transition profile designed to compensate for differences in height of up to 12.5 mm

DURATRANS **anodised aluminium** profiles are provided with a special finish that can usually prevent any subsequent alterations to the surface. Visible surfaces must nevertheless be protected from cement-based materials. Damage may occur as a result of items scratching or scraping the surface.

DURATRANS **brass** profiles are appropriate for use in domestic and industrial areas. They are resistant to major stresses and mostly resistant to chemicals generating during the laying of tiles. Important: brass oxidises in air, especially in humid conditions. The surface then develops a patina and its appearance is thus altered.

For all products and materials, the following applies: The suitability of the material with regard to the expected mechanical loading and chemical exposure must be investigated carefully in each individual case. The generally recognised rules of good engineering practice must always be observed!

INSTALLATION:

1. DURATRANS profiles appropriate to the height of the tiles should be selected.
2. Tile adhesive should be applied around the junction using a serrated trowel.
3. Press the DURATRANS profile into the adhesive bed and align it. Follow any existing joints in the foundations.
4. Spread mortar over the entire surface of the joint.
5. Press in tiles firmly and align them so that they are flush with the top edge of the profile. Lay the tiles without leaving any gaps.
6. Allow a joint of 2-3 mm around the profile itself.
7. Then fill the space between the tiles and the profile with grout.

MAINTENANCE:

DURAFLEX profiles do not require any special maintenance. Oxidation layers may be removed using polish. Nevertheless, it is impossible to remove oxidation permanently. Cleaning agents should be free of hydrochloric and hydrofluoric acid and should not contain abrasives.

PRODUCT DATA:

MATERIAL:	– Aluminium natural – Aluminium anodised silver – Brass natural – Brass high gloss polished („Star“ with peel-off strip)
LENGTH:	100 cm / 250 cm
VISIBLE SURFACE:	14-17 mm
HEIGHT:	9 / 11 / 12,5 mm

DURAL GmbH & Co. KG

Südring 11

D-56412 Ruppach-Goldhausen

Tel. +49 (0) 2602/9261-0

Fax +49 (0) 2602/9261-50

welcome@dural.de