

BASIC-LINE

1/2

Ultra-flat, linear shower drainage channel for barrier-free, tiled shower rooms

DURAL

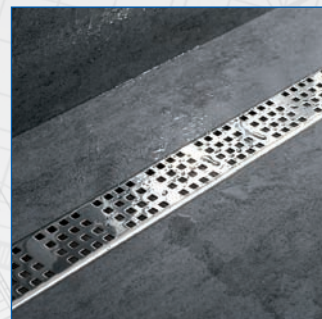

Materials:

The shower drainage channel and the grate are made of stainless steel (1.4301). The material and the design make for optimised strength and resistance to deformation. The electro-chemical finish minimises the build up of dirt on the insides of the shower drainage channels, while ensuring a reliable connection between the drainage channel and the composite seal and also enhancing corrosion resistance. The surface of the shower drainage channel has a metallic gloss finish, which repels dirt and is smoother than the original stainless material. The low height of the BASIC-LINE shower drainage channels also makes them ideally suited for conversion work and renovation projects (refurbishing existing buildings).

Mounting feet:

Installation is simple, quick and precise, with easy height adjustment. The drainage channel can be adapted to the existing screed height using the two mounting feet at the side. The drainage channel has a polystyrene insert and backing film to protect both it and the odour seal from contamination during the installation work.

Drainage channel drain and odour seal:

One of the most important factors for ensuring that drainage channels function perfectly is achieving the right technical design for the drain and the odour seal. The BASIC-LINE drainage system allows the odour seal to be easily and thoroughly cleaned right up to the drainpipe itself, which in turn guarantees a continuous drainage capacity of some 60 litres per minute over the entire lifetime of the shower drainage channel. The drainage capacity of the channel is designed to cope effortlessly with the large shower heads that are now finding increasing use.

DURAL GmbH & Co. KG

Postfach 1348

D-56403 Montabaur

Tel. +49 (0) 2602/9261-0

Fax +49 (0) 2602/9261-50

welcome@dural.de

Ultra-flat, linear shower drainage channel for barrier-free, tiled shower rooms



Where normally only one odour seal is used, the BASIC-LINE system uses dual drainage chambers, with two removable inlets. This makes it possible to perfectly clean both odour seal chambers.

The inlets are secured by a pivoting stainless steel pin which durably holds the inlets in place. The strainers that are inserted trap any coarse particles and, thanks to the double odour seal, the chambers only need to be cleaned half as often as otherwise.

Grates:

Our range of designer grates meets the needs of even the most exacting customers. The grates are made of high grade, stainless steel (DIN 1.4301) and are supplied either mechanically polished to a high gloss finish or brushed to a matt finish. The polished high gloss finish goes ideally with chrome-plated fittings.

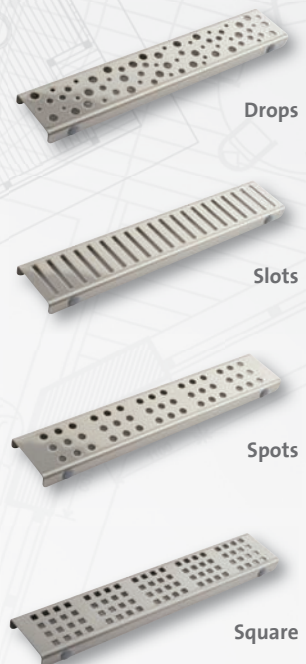
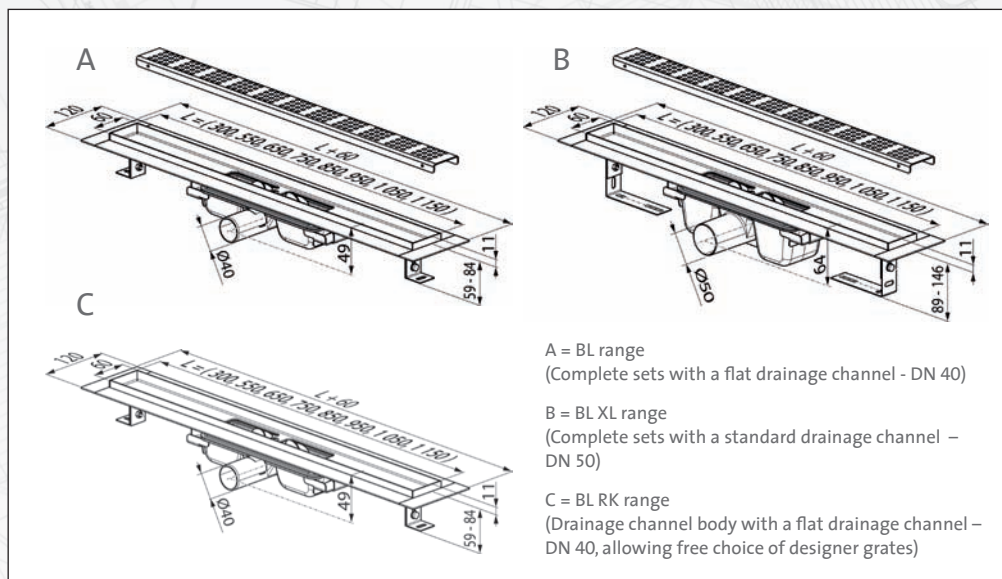

PRODUCT DETAILS:

MATERIAL:	Stainless steel (1.4301) – (drainage channel/grate)
MATERIAL THICKNESS (DESIGNER GRATE):	1.5 mm
INSTALLATION HEIGHT:	> 59 mm / 89 mm
PIPE CONNECTION:	DN 40 / DN 50 with double odour seal
DRAINAGE CAPACITY:	> 0.58 l/sec.
FORMATS (A, B, C):	BL 300 (360 x 120) – visible dimensions 300 x 60 mm BL 600 (610 x 120) – visible dimensions 550 x 60 mm BL 700 (710 x 120) – visible dimensions 650 x 60 mm BL 800 (810 x 120) – visible dimensions 750 x 60 mm BL 900 (910 x 120) – visible dimensions 850 x 60 mm BL 1000 (1010 x 120) – visible dimensions 950 x 60 mm BL 1100 (1110 x 120) – visible dimensions 1050 x 60 mm BL 1200 (1210 x 120) – visible dimensions 1150 x 60 mm

DURAL GmbH & Co. KG

Postfach 1348

D-56403 Montabaur

Tel. +49 (0) 2602/9261-0

Fax +49 (0) 2602/9261-50

welcome@dural.de